

GoldenPower®

GLR6A

TECHNICAL SPECIFICATION

技術規格書

ALKALINE MANGANESE DIOXIDE BATTERY

環保鹼性鋅錳電池

Approved	
General Manager:	Date:



DATE 日期 : 2011/07/28
SPEC. NO. 編號 : GP001-GLR6A
REVISION 版次 : 04

GOLDEN POWER CORPORATION (HK) LTD.

金力企業（香港）有限公司

Flat C, 20/F, Block 1, Tai Ping Industrial Centre, 57 Ting Kok Road, Tai Po, N.T. Hong Kong.

香港新界大埔汀角路 57 號太平工業中心第一座 20 樓 C 室

Tel 電話 : (852) 3125 2288 Fax 傳真: (852) 3125 2000 / (852) 3125 2001

E-mail 電郵 : battery@goldenpower.com Web Page 網址 : <http://www.goldenpower.com>

The Manufacturer reserves the right to modify product specification and data stated herein without prior notice
生產商對本產品技術規格如有更改，不另行通知。

1. Scope 概要

This specification is applicable to Golden Power's Greenergy Power P+US Alkaline Battery

這技術規格是應用於金力: 勁・環保系列 - 勁力能量鹼性電池

Model No. / 型號 : GLR6A

1.1 Designations 型號

Golden Power:	GLR6A	IEC:	LR6	Others:	AA, E91, 4006
JIS:	AM-3	ANSI:	15A		

1.2 Reference Document 參考標準

IEC 60086-1 (2011-02) - Primary Batteries - Part 1: General

IEC 60086-2 (2011-02) - Primary Batteries - Part 2: Physical and Electrical Specification

IEC 60086-5 (2011-02) - Primary Batteries - Part 5: Safety of batteries with aqueous electrolyte

2. Chemical System Alkaline-Manganese Dioxide

* MERCURY AND CADMIUM ARE NOT ADDED

化學構成

鹼性鋅錳

* 沒有加進汞及鎘

3. Nominal Voltage 1.5V

標稱電壓

4. Average Weight 22.5g

平均重量

5. Nominal Capacity 2300mAh

標稱容量

Condition : continuous discharge at $20 \pm 2^\circ\text{C}$ under 43Ω load for 4hrs/day to EPV 0.9V

條件 : 利用 43Ω 電阻, 在 $20 \pm 2^\circ\text{C}$ 每日放電 4 小時, 終止電壓為 0.9V

6. Electrical Characteristics 電性能

Test Conditions tested within 30 days after delivery
條件 收貨後 30 天內測試

Load resistance : Temperature : Measuring time :
負載電阻 : $3.9\Omega \pm 0.5\%$ 測量溫度 : $20 \pm 2^\circ\text{C}$ 測量時間 : 0.3 sec

	Off-load voltage 空載電壓 OCV (V)	On-load voltage 負載電壓 CCV (V)	Test Specification 驗收規則
New Battery 新電	1.58	1.45	MIL-STD-105E, Class II, Double Sampling, AQL=0.4
After 3 mth. at temp.=45°C 在 45°C 下存放 3 個月	1.56	1.40	
After 12 mth. room temp. 在室溫下存放 12 個月	1.56	1.40	

7. Service Output 放電性能

Test Conditions tested within 30 days after delivery
條件 收貨後 30 天內測試
Temperature $20 \pm 2^\circ\text{C}$
測量溫度

Standard 標準	Discharge Condition 放電條件			Average Minimum Discharge Time 平均最少放電時間		
	Discharge load 放電負載	Daily discharge time 每天放電時間	EPV 終止電壓 (V)	New Battery 新電池	After 3 mth. at temp.=45°C 在 45°C 下 存放 3 個月	After 12 mth. at room temp. 在室溫下 存放 12 個月
IEC	43Ω	4h/d	0.9V	80 h	72 h	72 h
IEC	3.9Ω	1h/d	0.8V	5 h	4.6 h	4.6 h
IEC	100mA	1h/d	0.9V	18.9 h	17.7 h	17.7h
IEC	250mA	1h/d	0.9V	5 h	4.7h	4.7 h
IEC	1000mA	10s/50s, 1h/d	0.9V	220 pulses	202.4 pulses	202.4 pulses
IEC	24Ω	15s/m, 8h/d	1.0V	33 h	29.7 h	29.7 h
IEC	3.3Ω	4m/h, 8h/d	0.9V	286.8 min	258.1 min	258.1 min
REF	10Ω	1h/d	0.9V	16.5 h	15.6 h	15.6 h
REF	10Ω	24h/d	0.9V	17 h	15.3 h	15.3 h

Acceptance Criteria / 驗收標準 :

- (1) 9 pieces of battery will be tested for each discharging standard.
每一種放電條件取 9 只電池進行放電。
- (2) The result of the average discharging time from each discharging standard shall be equal to or more than the average minimum time requirement; and no more than one battery has a service output less than 80% of the specified requirement.
平均放電時間等於或大於平均最少放電時間的規定值，而放電時間少於規定值 80% 的電池數量不大於 1，則認為電池的放電時間符合要求。
- (3) One re-test is allowed to confirm the previous result.
若以上結果不合格，可作一次重驗。

8. Electrolyte Leakage Proof Characteristics 漏液性能測試

Item 項目	Condition 條件	Period 時間	Requirements 要求	Acceptance Standard 驗收標準
Over-discharge Characteristics 過放性能測試	1) 10Ω continuous discharge 10Ω 連放 2) storage temp / 存放溫度 = 20 ± 2°C, 3) Relative Humidity / 相對濕度 = 65 ± 20% RH	48 Hrs	There shall be no deformation exceeding the specified dimensions, nor leakage recognized by human eye	N=30, Ac=1, Re=2
Storage Characteristics 存放條件測試	1) storage temp / 存放溫度 = 60 ± 2°C, 2) Relative Humidity / 相對濕度 90 ± 5%RH	30 days	以目視檢查電池沒有變形，沒有發現漏液	N=30, Ac=1, Re=2

9. Safety Characteristics 安全性能

Item 項目	Condition 條件	Period 時間	Requirements 要求	Acceptance Standard 驗收標準
Short circuit Characteristics 短路性能	Temp.: 20 ± 2°C	24 hrs	There shall be no explosion of battery 電池沒有爆炸	N=9, Ac=0, Re=1
Wrongly Installed 不正確安裝	Connect 4 batteries in series with 1 battery reversed & store in Rm. Temp 串聯 4 只電池，其中 1 只反向安裝及在室溫存放	24 hrs		

10. Marking 標記

The following markings will be printed, stamped or impressed on the body of the battery:
在電池外標明以下內容：

- | | | |
|---|---|---|
| 1) Designation
型號 | GLR6A Alkaline | |
| 2) Manufacturer's name or abbreviation
製造商 | "Golden Power" |  |
| 3) Polarity Marking 極性標記 | "+" & "-" | |
| 4) Others
其他 | 4.1 1.5 V GLR6A LR6 AM3
4.2 AA SIZE
4.3 Made in China
4.4 Greenergy Power P+US Alkaline
4.5 Marking of Separate Collection |  |
| 5) Warning
警告 | Do not dispose of in fire, recharge, put in backwards, mix with used or other battery types – may explode or leak and cause personal injury.No Mercury & Cadmium Added. | |

11. Caution for Use 注意事項

1. Since the battery is not manufactured for recharging, there are risks of electrolyte leakage or causing damage to the device if the battery is charged.
請勿對電池進行充電，這樣可能會導致電池漏液，發生危險及對相關的充電設備造成破壞。
2. The battery shall be installed with its "+" and "-" polarity in correct position, otherwise may cause short-circuit.
在安裝電池時，請把電池安裝在正確的方向，若安裝不正確或會造成短路。
3. Short-circuiting, heating, disposing of into fire and disassembling the battery are prohibited.
請勿將電池短路、加熱、投入火中或試圖拆開。
4. Battery cannot be forced discharge, which lead to excess internal gas generation and, may result in bulging, leakage and de-crimping of cap.
不可強行對電池進行放電，這樣可能會導致電池漏液或發生危險。
5. New and used batteries cannot be used at the same time, when replaced batteries recommend to replace all and with the same brand type.
請盡量避免把新電池及已用過的電池同時使用。
6. Exhausted batteries should be removed from compartment to prevent over-discharge, which cause leakage & damage to the device.
請把已耗盡的電池從用電的產品上移走，避免對電池進行過放，而引起電池漏液。
7. Direct soldering is not allowed, which will damage the battery.
請勿焊接電池，這樣會對電池造成損害。
8. Battery should be kept out of the reach of children to prevent swallow, in case of accident should contact physician at once.
電池應放在小童不可接觸的地方，以免小童誤吞電池。
9. The battery should not be dismantled and deformed.
切勿把電池拆開。

12. Shelf Life 3 years after delivery under proper storage conditions

電池存放期 於常溫及合適環境可儲存 3 年。

Storage Conditions 存放條件

Temperature 20 ± 2°C

溫度

Relative humidity 55 ± 20% RH

相對濕度

13. Discharge Curves 放電圖 : Figure 1 / 圖 1

Test temperature / 測試溫度	20 ± 2°C
Discharge Method / 放電方法:	1) 43Ω, 4hr/day Fig. 1

14. Battery Dimension Refer to Drawing DWG-S-001

電池尺寸 參考圖紙 DWG-S-001

15. Packaging Requirements 包裝要求

15.1 For standard bulk package specification, please refer to ANNEX 1.

工業包裝標準, 可參考附件 1

15.2 Packaging labels should be legible and permanent, label defects and special packaging identifications shall conform to mutually agreed specification and / or approved samples

包裝用標籤須符合易於辨認, 清楚顯示及恆久性要求, 標籤質量問題和其他特別包裝要求須另訂協議或按雙方樣板確認.

15.3 Other packaging for shipment and sales shall conform to mutual agreed packaging specification

客方特定包裝標準須另訂協議確認

16. Compliance & Environmental Information 法規及環保信息

This product complies with EU RoHS Directive 2002/95/EC, Battery Directive 2006/66/EC and REACH Directive and REACH regulation EC. No. 1907/2006. For MSDS information, please refer to ANNEX 2

此產品符合 歐盟 RoHS 指令 2002/95/EC, 電池指令 2006/66/EC 及 REACH 法規 EC. No. 1907/2006 有關 MSDS 資料可參考 附件 2

DISCHARGE CURVE 放電圖

Fig. 1 :

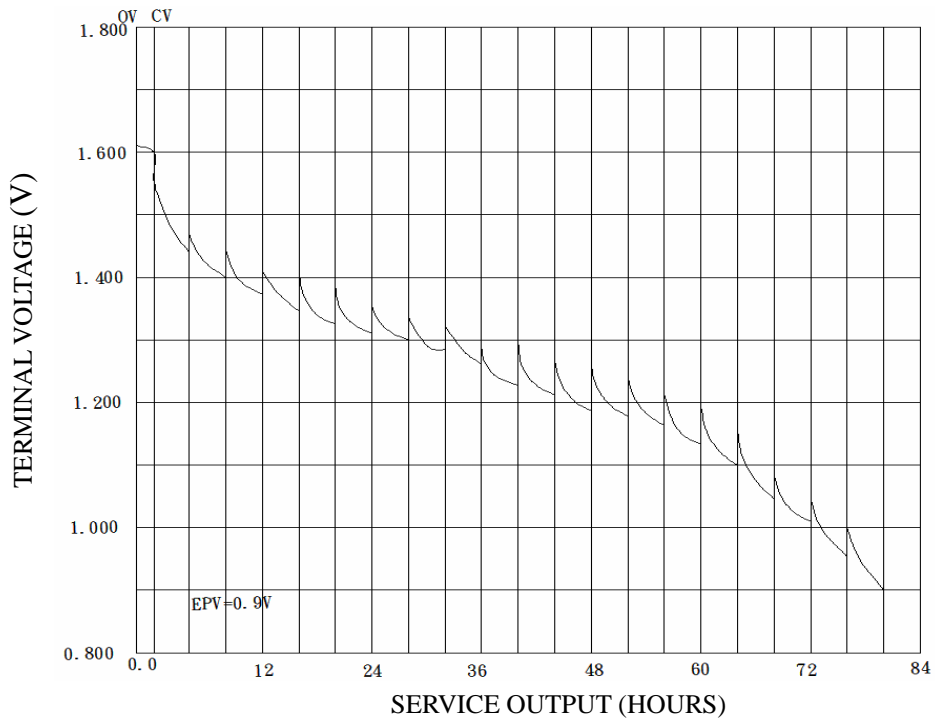

Test temperature / 測試溫度	20 ± 2°C
Discharge Method / 放電方法:	1) 43Ω, 4hr/day

GLR6A BATTERY DIMENSION AND STRUCTURE

GLR6A 電池外形及尺寸

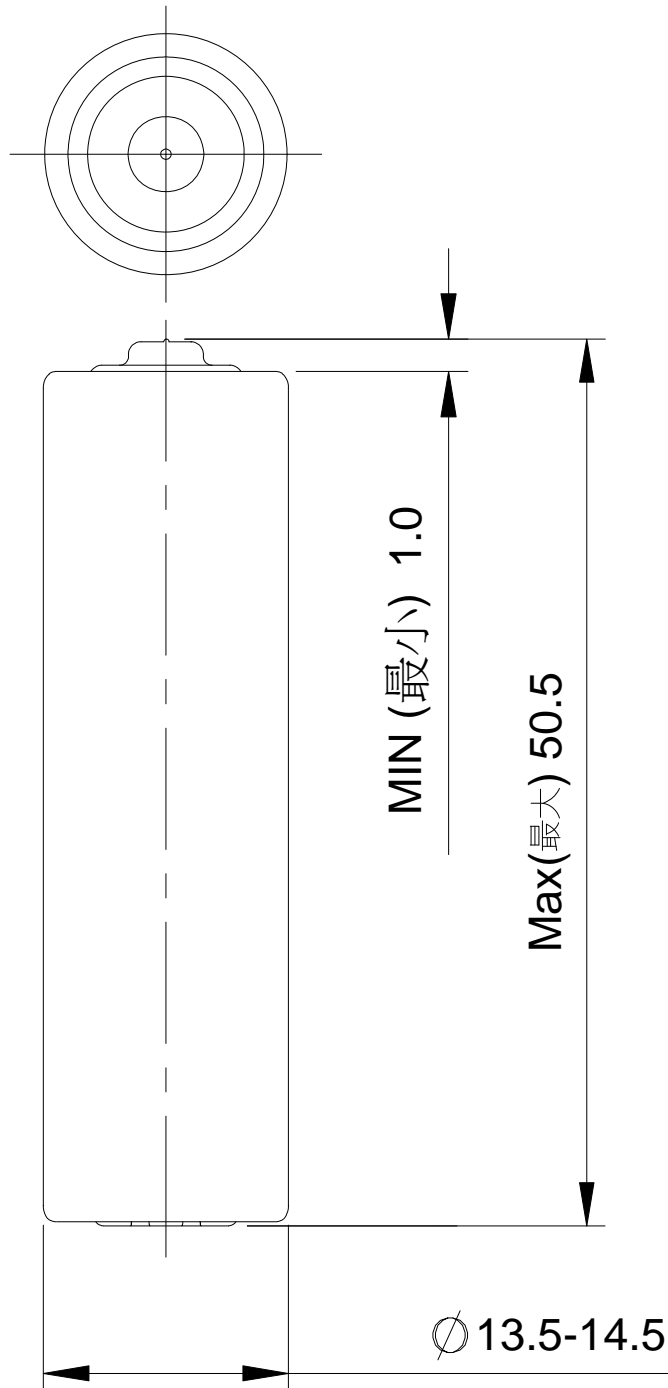

GOLDEN POWER CORPORATION (HK) LTD.
金力企業(香港)有限公司

MODEL(型號): GLR6A		DWG No.(圖號): DWG-S-001	
SCALE(比例): NTS	DIM(單位): mm	Approved by (審核):	
DATE(日期): 15/9/05	DRAWN BY(繪制): Kelvin	Cecilia Chu	
TOLERANCES (公差) LINEAR ± 1 ANGLUAR $\pm 1/4'$ 3rd ANGLE PROJECTION (第三角度視圖)			

ANNEX 1 : Standard Bulk Package specification

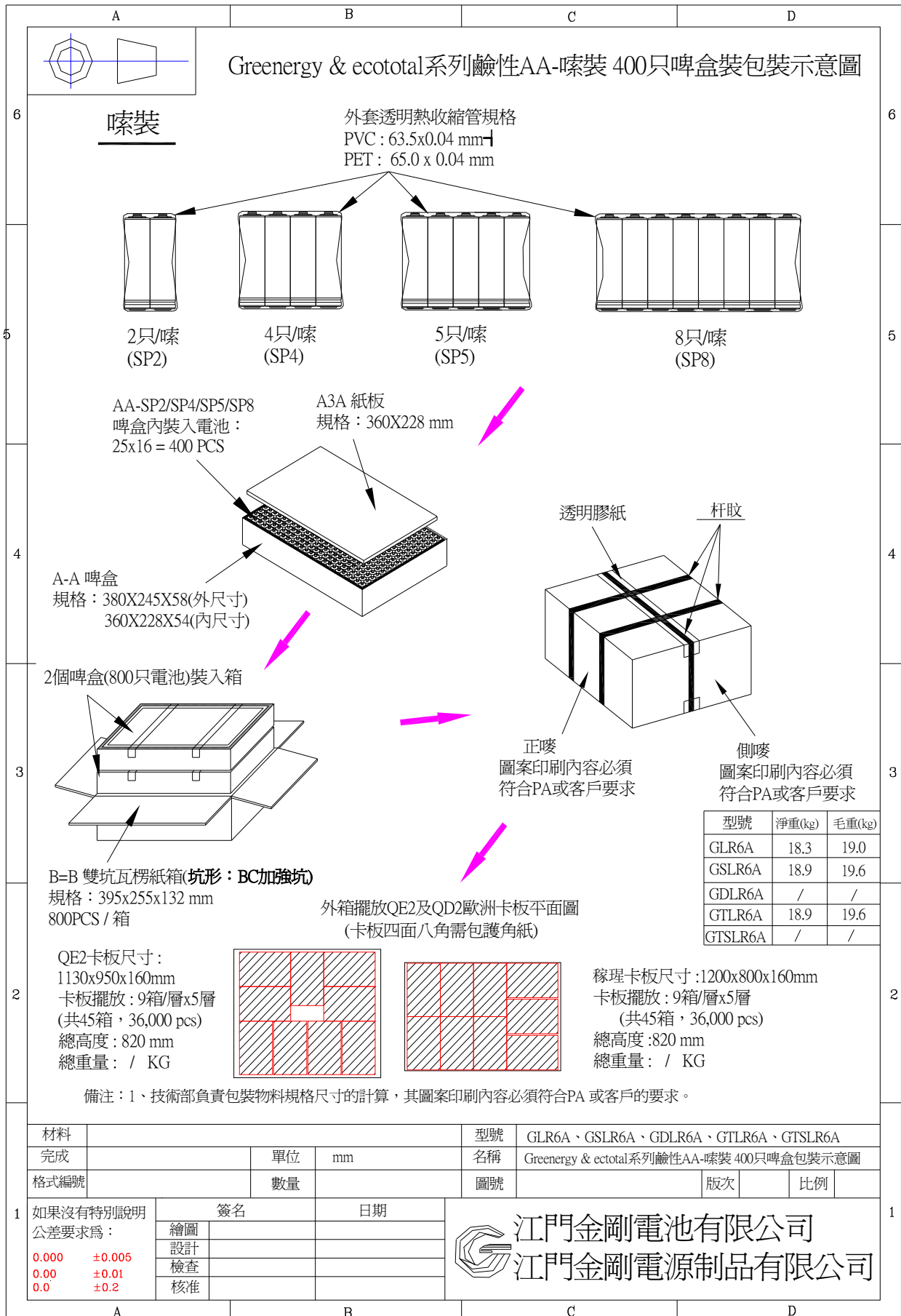

ANNEX 2 : Material Safety Data Sheet MSDS

Material Safety Data Sheet

IDENTITY (As Read on Label and Line) GLR6A ALKALINE BATTERY	Notice: Blank spaces are not permitted. If any item is not applicable, or no information is available, the space must be marked to indicate that.
--	---

Section I

Manufacturer's Name Golden Power Corporation (HK) Ltd.	Telephone Number (852) 3125 2288
Address (Number, Sheet, City, State, and ZIP Code) Flat C, 20/F., Block 1, Tai Ping Industrial Centre, 57 Ting Kok Road, Tai Po, N.T., Hong Kong	Fax Number (852) 3125 2000 / 3125 2001
	Date Prepared July 28, 2011
Signature of Preparer (optional)	

Section II – Hazardous Ingredients/Identity Information

Hazardous Components (Specific Chemical Identity, Common Names)	(contents, %/wt)	CAS No.
Manganese Dioxide (MnO ₂)	37.07%	1313-13-9
Zinc (Zn)	17.43%	7440-66-6
Potassium Hydroxide (KOH)	6.82%	1310-58-3
Graphite (C)	2.56%	7782-42-5
Cadmium (Cd)	≤ 0.0005%	7440-43-9
Mercury (Hg)	≤ 0.0002%	7439-97-6
Lead (Pb)	≤ 0.001%	7439-92-1

Section III – Physical/Chemical Characteristics

Boiling Point KOH aqua solution = 140 °C	Specific Gravity (H ₂ O=1) MnO ₂ = 4.4, Zn = 7.1, KOH = 2.0
Vapor Pressure (mmHg) KOH aqua solution = 3mmHg at 20 °C	Melting Point MnO ₂ decompose at 535°C Zn = 420 °C, KOH aqua = -35 °C
Vapor Density (Air = 1)	Evaporation Rate (Butyl Acetate = 1)

Solubility in Water KOH – complete

Appearance and Color

MnO₂ is a black powder, Graphite is also a black powder, Zinc is a silver metal.
KOH aqua is a colorless liquid with stimulative order.

Section IV – Fire and Explosion Hazard Data

Flash Point (Method Used) Incombustible	Flammable Limits Not Available	LEL	UEL
--	-----------------------------------	-----	-----

Extinguishing Media: See Special Fire Fighting Procedure

Special Fire Fighting Procedure: In case of fire in an adjacent area, use water, CO₂ or dry chemical extinguishers if cells are packed in their original containers since the fuel of the fire is basically paper products. For bulk quantities of unpackaged cells use LITH-X (Graphite Base). In this case, do not use water.

As with any fire, wear self-contained breathing apparatus to avoid inhalation of hazardous decomposition products.

Unusual Fire and Explosion Hazards

Section V – Reactivity Data

Stability	Unstable		Conditions to Avoid Do not short circuit, charge or dispose of in fire.
	Stable	√	

Incompatibility (Materials to Avoid) Hazardous polymerization will not occur.

Hazardous Decomposition or Byproducts Not Available

Hazardous Polymerization	May Occur		Conditions to Avoid
	Will Not Occur	√	

Section VI – Health Hazard Data

Route(s) of Entry.	Inhalation?	Yes	Skin?	Yes	Ingestion?	Yes
--------------------	-------------	-----	-------	-----	------------	-----

Health Hazards (Acute and Chronic) These chemicals are contained in a sealed can. Risk of exposure occurs, only if battery is mechanically or electrically abused. The most likely risk is acute exposure when a cell vents KOH is caustic alkali and attack the skin and eyes. Contact of electrolyte with skin and eyes should be avoided.

Section VII – Ecological Information

Cardnogenicity	NTP?	Not Available	IARC Monographs?	Not Available	OSHA Regulated?	Not Available
----------------	------	---------------	------------------	---------------	-----------------	---------------

Signs and Symptoms of Exposure KOH can cause chemical burn upon contact with skin.

Medical Conditions Generally Aggravated by Exposure An acute exposure will not generally aggravate any medical help.

Section VIII –Emergency and First Aid Procedures

In case of skin contact with content of battery, flush immediately with water.
For eye contact, flush with copious amount of water for 10 minutes. If imitation persists, get medical help.

Section IX - Precautions for Safe Handling and Use

Steps to Be Taken in Case Material is Released or Spilled Wipe out by wet duster.

Section X - Waste Disposal Method

General abandonment

Section XI - Precautions to Be Taken in Handling and Storing

Avoid mechanical or electrical abuse.

Section XII - Other Precautions

Do not short circuit, charge or dispose of in fire. Battery may explode or leak.

Section XIII - Control Measures

Respiratory Protection (Specify Type) Not Available

Ventilation	Local Exhaust	Not Available	Special	Not Available
	Mechanical (General)	Not Available	Other	Not Available

Protective Gloves	Butyl	Eye Protection	Safety Glasses
-------------------	-------	----------------	----------------

Other Protective Clothing or Equipment Not Available

Work / Hygienic Practices Not Available

Section XIV – Regulatory Information

Not Available

Section XV – Other Information

Not Available

Section XVI – Transportation Information

Golden Power batteries are considered to be “dry cell” batteries and are not regulated for purposes of transportation with reference to requirements of

1. U.S. Department of Transportation (DOT), Special Provision 130, i.e. “Batteries, dry are not subject to the requirements of this subchapter only when they are offered for transportation in a manner that prevents the dangerous evolution of heat (for example, by the effective insulation of exposed terminals)”.
2. International Civil Aviation Administration (ICAO) and International Air Transport Association (IATA), Special Provision A123, i.e. “An electrical battery or battery powered device having the potential of dangerous evolutions of heat that is not prepared so as to prevent a short-circuit (e.g. in the case of batteries, by the effective insulation of exposed terminals; or in the case of equipment, by disconnection of the battery and protection of exposed terminals) is forbidden from transportation.”
3. International Maritime Dangerous Goods Regulations (IMDG), Special Provision 304, i.e. “Batteries, dry, containing corrosive electrolyte which will not flow out of the battery case is cracked are not subject to the provisions of this Code provided the batteries are securely packed and protected against short-circuits.

Examples of such batteries include alkali-manganese, silver oxide, zinc carbon, nickel metal hydride and nickel-cadmium batteries.
